

MATHEMATICS

Mathematics Chart

LENGTH

Metric	Customary
1 kilometer = 1000 meters	1 mile = 1760 yards
1 meter = 100 centimeters	1 mile = 5280 feet
1 centimeter = 10 millimeters	1 yard = 3 feet
	1 foot = 12 inches

CAPACITY AND VOLUME

Metric	Customary
1 liter = 1000 milliliters	1 gallon = 4 quarts
	1 gallon = 128 ounces
	1 quart = 2 pints
	1 pint = 2 cups
	1 cup = 8 ounces

MASS AND WEIGHT

Metric	Customary
1 kilogram = 1000 grams	1 ton = 2000 pounds
1 gram = 1000 milligrams	1 pound = 16 ounces

TIME

1 year = 365 days
1 year = 12 months
1 year = 52 weeks
1 week = 7 days
1 day = 24 hours
1 hour = 60 minutes
1 minute = 60 seconds

Metric and customary rulers can be found on the separate Mathematics Chart.

Mathematics Chart

Perimeter	rectangle	$P = 2l + 2w$ or $P = 2(l + w)$
Circumference	circle	$C = 2\pi r$ or $C = \pi d$
Area	rectangle	$A = lw$ or $A = bh$
	triangle	$A = \frac{1}{2}bh$ or $A = \frac{bh}{2}$
	trapezoid	$A = \frac{1}{2}(b_1 + b_2)h$ or $A = \frac{(b_1 + b_2)h}{2}$
	circle	$A = \pi r^2$
Surface Area	cube	$S = 6s^2$
	cylinder (lateral)	$S = 2\pi rh$
	cylinder (total)	$S = 2\pi rh + 2\pi r^2$ or $S = 2\pi r(h + r)$
	cone (lateral)	$S = \pi rl$
	cone (total)	$S = \pi rl + \pi r^2$ or $S = \pi r(l + r)$
	sphere	$S = 4\pi r^2$
Volume	prism or cylinder	$V = Bh^*$
	pyramid or cone	$V = \frac{1}{3}Bh^*$
	sphere	$V = \frac{4}{3}\pi r^3$
<i>*B represents the area of the Base of a solid figure.</i>		
Pi	π	$\pi \approx 3.14$ or $\pi \approx \frac{22}{7}$
Pythagorean Theorem		$a^2 + b^2 = c^2$
Distance Formula		$d = \sqrt{(x_2 - x_1)^2 + (y_2 - y_1)^2}$
Slope of a Line		$m = \frac{y_2 - y_1}{x_2 - x_1}$
Midpoint Formula		$M = \left(\frac{x_1 + x_2}{2}, \frac{y_1 + y_2}{2} \right)$
Quadratic Formula		$x = \frac{-b \pm \sqrt{b^2 - 4ac}}{2a}$
Slope-Intercept Form of an Equation		$y = mx + b$
Point-Slope Form of an Equation		$y - y_1 = m(x - x_1)$
Standard Form of an Equation		$Ax + By = C$
Simple Interest Formula		$I = prt$

DIRECTIONS

Read each question. Then fill in the correct answer on your answer document. If a correct answer is not here, mark the letter for “Not here.”

SAMPLE A

Find the slope of the line $2y = 8x - 3$.

A $-\frac{3}{2}$

B 4

C 8

D Not here

SAMPLE B

Janice uses a rectangular box to store her art supplies. The dimensions of the rectangular box are 22.5 inches by 14 inches by 11.5 inches. What is the volume of this box in cubic inches?

Record your answer and fill in the bubbles on your answer document. Be sure to use the correct place value.



1 An artist studies human proportions in order to make realistic drawings. He observes that a person's kneeling height, y , is $\frac{3}{4}$ of the person's standing height, x . Which equation best represents this relationship?

A $y = \frac{3}{4}x$

B $y = -\frac{3}{4}x$

C $y = x - \frac{3}{4}$

D $y = x + \frac{3}{4}$

2 In a high school auditorium, 1 junior and 2 sophomores are seated randomly together in a row. What is the probability that the 2 sophomores are seated next to each other?

F $\frac{1}{9}$

G $\frac{1}{3}$

H $\frac{2}{3}$

J $\frac{5}{6}$

- 3 Karen jogs at a steady pace up a hill in her neighborhood. She then runs down the hill, and her speed increases. Which graph best describes this situation?

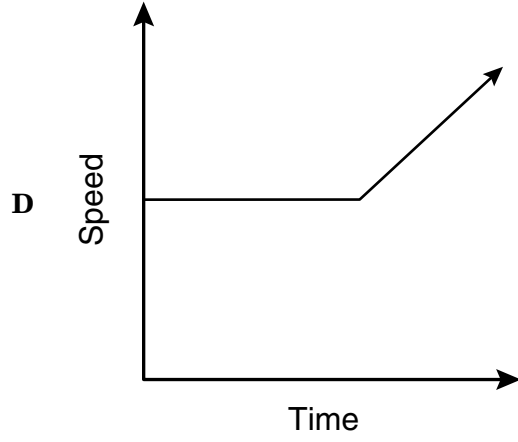
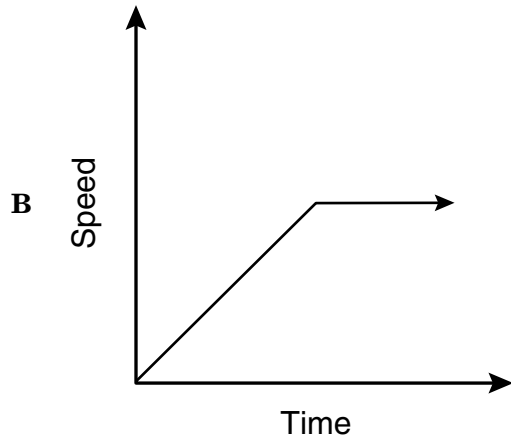
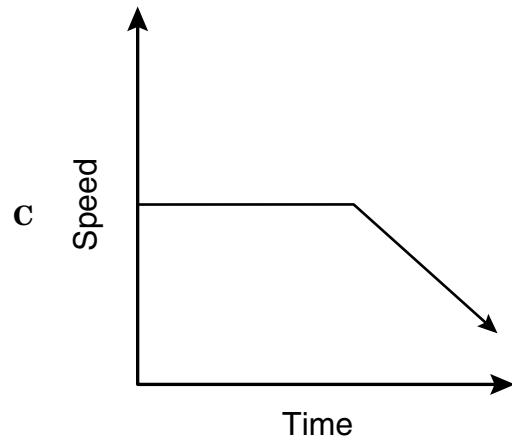
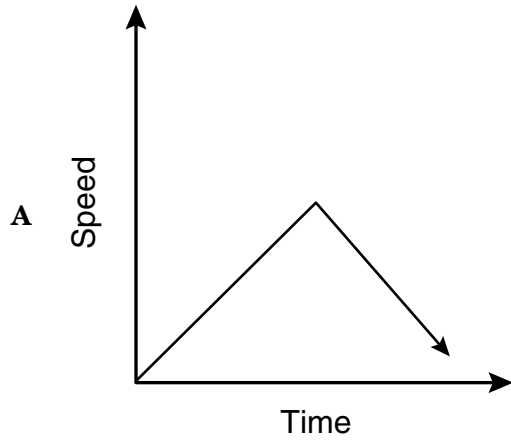

- 4 The graph below shows the height of a baseball from the time it is thrown from the top of a building to the time it hits the ground.

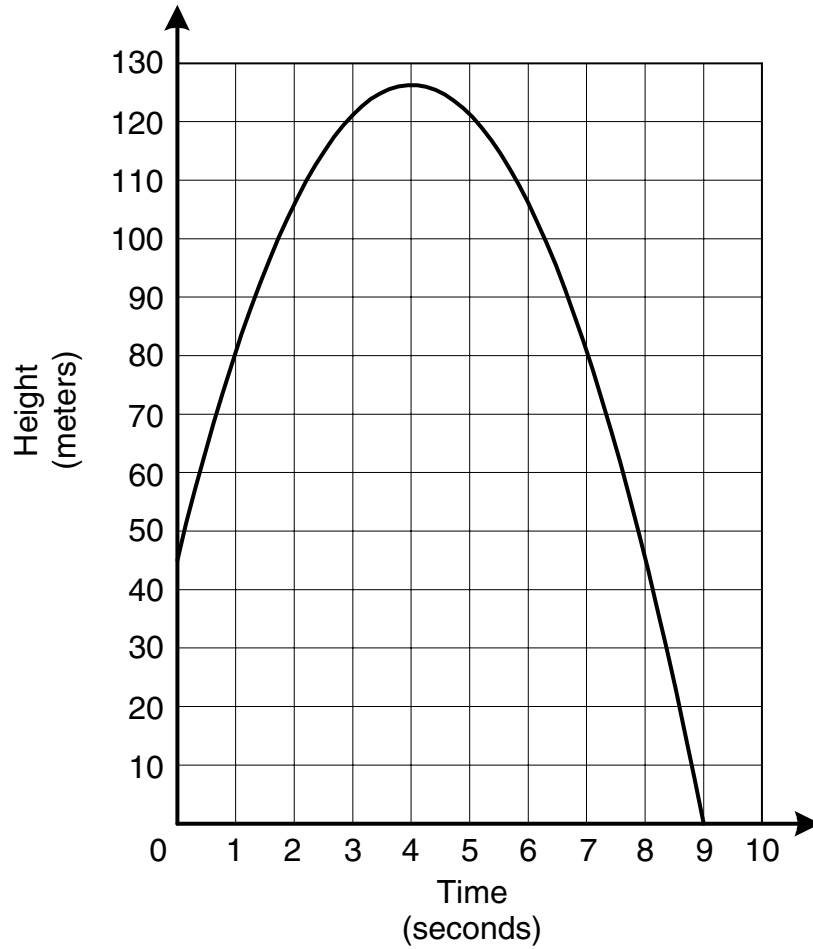

How much time elapses while the baseball is 80 meters or more above the ground?

- F** 1 sec
- G** 9 sec
- H** 7 sec
- J** 6 sec

- 5 Use the table to determine the expression that best represents the number of diagonals of any convex polygon having n sides.

Polygon	Number of Sides	Number of Diagonals
Triangle	3	0
Quadrilateral	4	2
Pentagon	5	5
Hexagon	6	9
Heptagon	7	14
Octagon	8	20

A $n - 3$

B $\frac{n - 3}{2}$

C $\frac{n(n - 3)}{2}$

D $n(n - 3)$

- 6 Which set of dimensions corresponds to a rectangular prism similar to the one shown below?

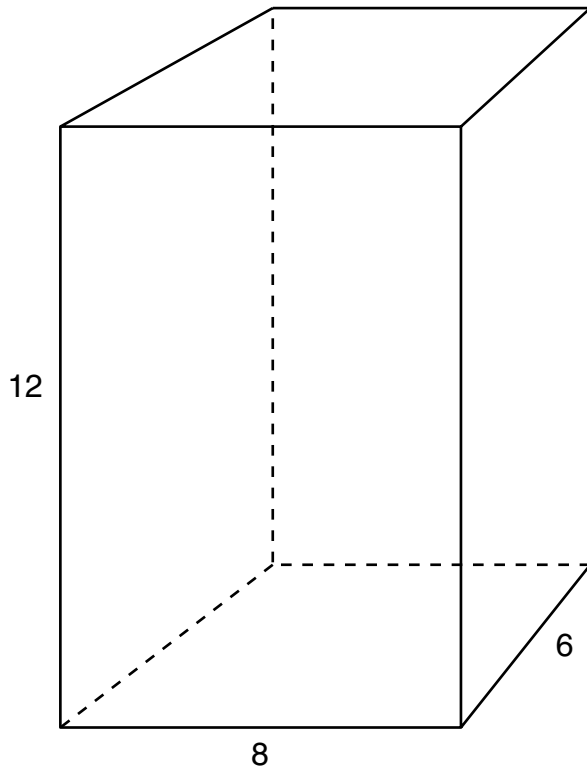

- F** 2 units by 3 units by 4 units
G 4 units by 2 units by 8 units
H 2 units by 1 unit by 6 units
J 4 units by 3 units by 6 units
- 7 Doris had a circular garden with a radius of 30 feet. She used all of the fencing from the circular garden to enclose a square garden. The length of each side of Doris's square garden was approximately —
- A** 47 feet
B 94 feet
C 120 feet
D 188 feet

- 8 What are the coordinates of the x -intercept of the equation $-3y = 8 - 2x$?

- F** $(-2, 0)$
G $(0, -\frac{8}{3})$
H $(\frac{2}{3}, 0)$
J $(4, 0)$
- 9 How many 2-inch cubes can be placed completely inside a box that is 8 inches long, 2 inches wide, and 6 inches tall?
- A** 8
B 12
C 24
D 48

10 Which pair of the following polygons is congruent?

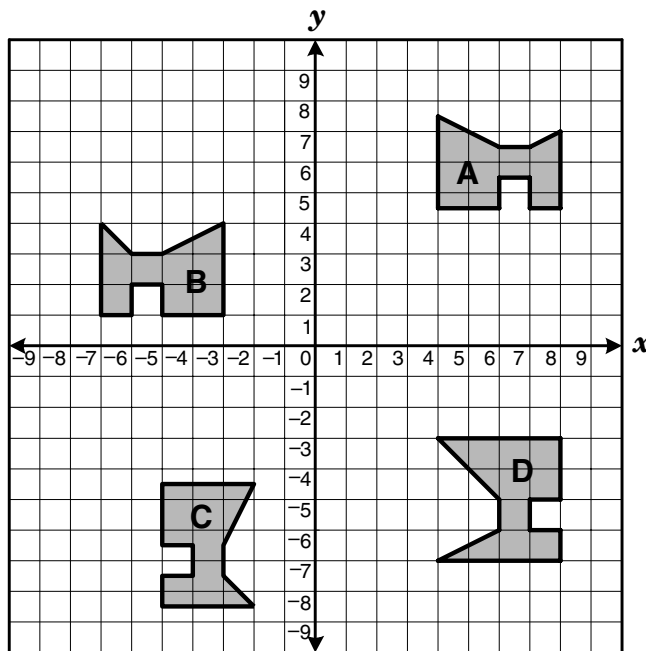

- F Polygon A and Polygon C
- G Polygon B and Polygon D
- H Polygon A and Polygon B
- J Polygon B and Polygon C

11 Let a represent the average speed in miles per hour a car traveled on a trip. Let $f(t)$ represent the distance in miles the car had traveled t hours after the beginning of the trip. The function $f(t)$ is best represented by —

- A $t^2 + a$
- B at^2
- C $t + a$
- D at

- 12 A kite string is 220 feet long from the kite to the ground. The string makes a 45° angle with the ground.

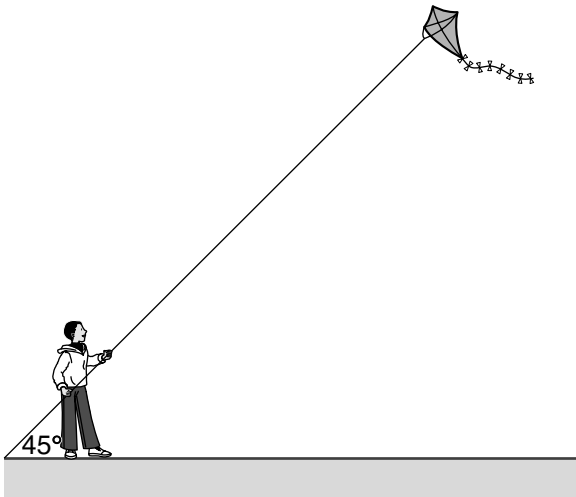

About how high off the ground is the kite?

- F 110 ft
- G 127 ft
- H 156 ft
- J 311 ft

- 13 What are the slope and y -intercept of the equation of the line graphed below?

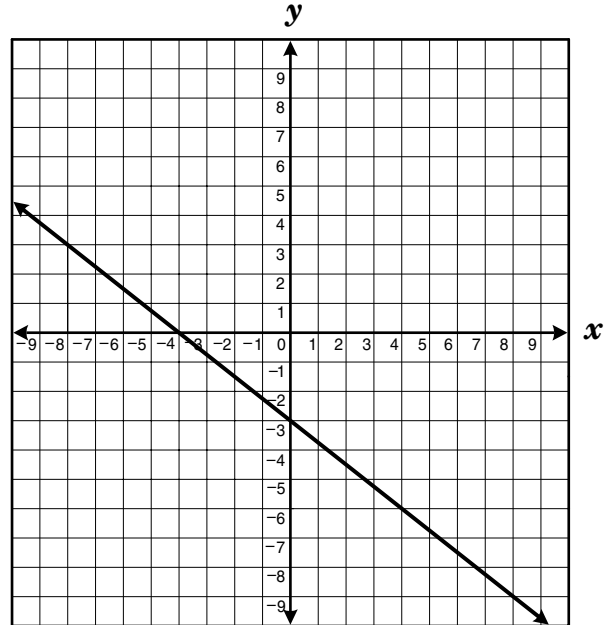

- A $m = -\frac{3}{4}$
 $b = -4$
- B $m = -\frac{4}{3}$
 $b = -4$
- C $m = -\frac{4}{3}$
 $b = -3$
- D $m = -\frac{3}{4}$
 $b = -3$

- 14 Jamal has a game with 2 groups of tiles. The first group of 26 tiles is labeled with all the letters of the alphabet. The second group of 10 tiles is numbered 0 through 9. If Jamal draws 1 letter tile and 1 number tile at random, what is the probability that he will draw a letter in his name and an odd number?

F $\frac{1}{13}$

G $\frac{5}{52}$

H $\frac{1}{4}$

J $\frac{7}{26}$

- 15 Which of the following best represents the front view of the solid shown below?

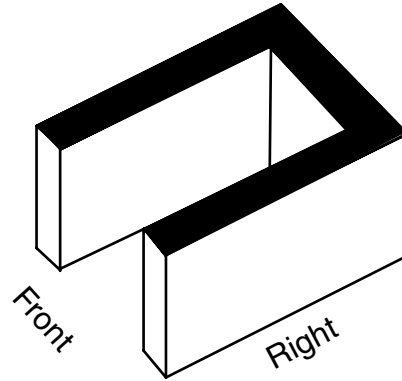

A



B

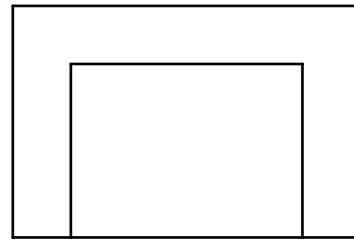

C

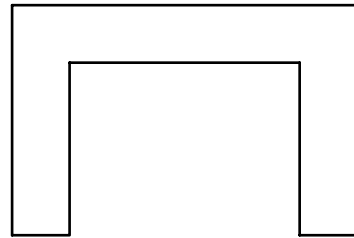

D

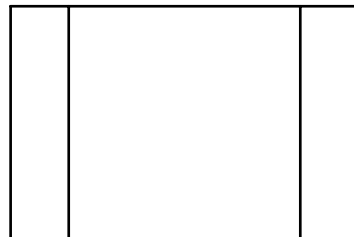

- 16 Which of the following best describes the graph of the equations below?

$$2y = 3x + 2$$

$$4y = 6x + 1$$

- F The lines have the same y -intercept.
- G The lines have the same x -intercept.
- H The lines are perpendicular.
- J The lines are parallel.

- 17 The graph of a line is shown below.

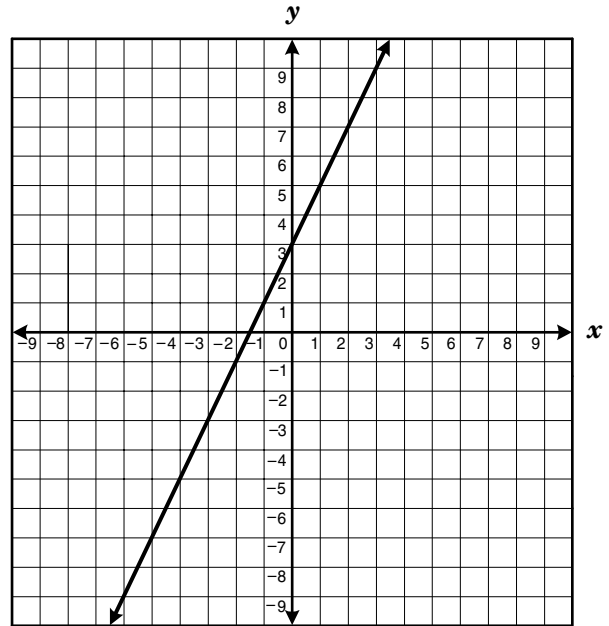

If the slope of this line is multiplied by -1 and the y -intercept decreases by 2 units, which linear equation represents these changes?

A $y = -2x + 1$

B $y = -x + 1$

C $y = -x - 1$

D $y = -\frac{1}{2}x - 1$

- 18** Given: Two angles are supplementary. The measure of one angle is 20° more than the measure of the other angle.

Conclusion: The measures of the angles are 70° and 90° .

This conclusion —

- F** is contradicted by the first statement given
- G** is verified by the first statement given
- H** invalidates itself because a 90° angle cannot be supplementary to another
- J** verifies itself because 90° is 20° more than 70°

- 19** Megan is using an equilateral triangle as part of a design on a sweatshirt. Each side of the triangle is 12 inches long. Megan is sewing a line of sequins from the midpoint of one side of this triangle to the opposite vertex. Approximately how long will the line of sequins be?

- A** 13.4 in.
- B** 10.4 in.
- C** 8.5 in.
- D** 5.2 in.

20 Which graph best represents the inequality $x + 2y \leq -14$?

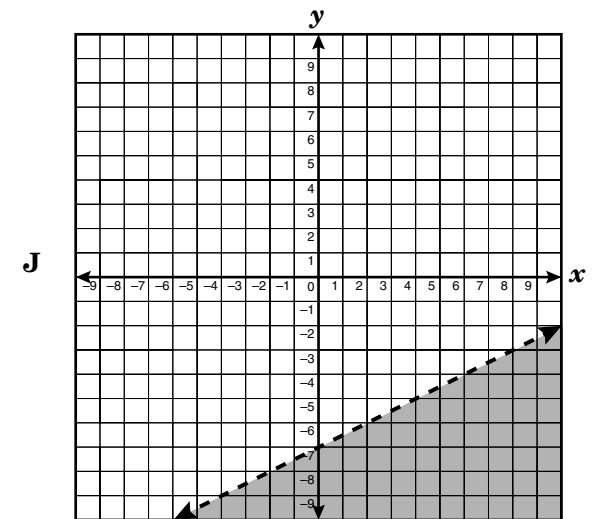
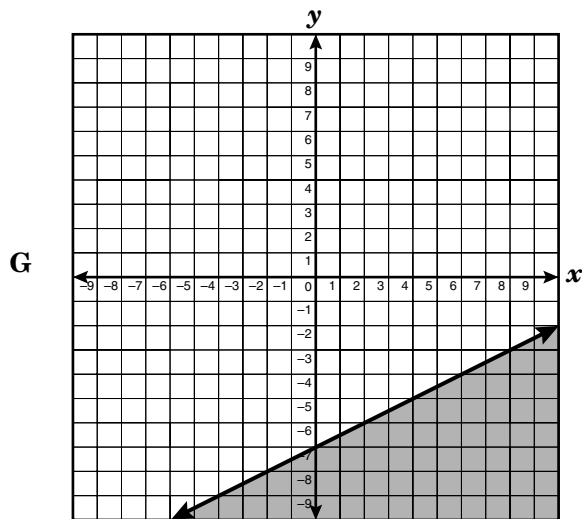
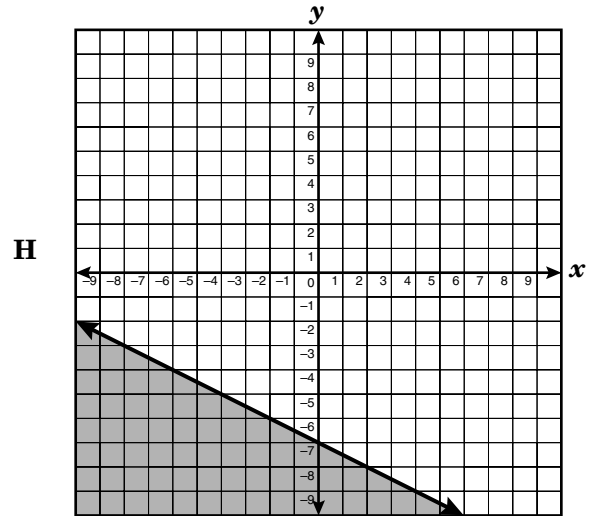
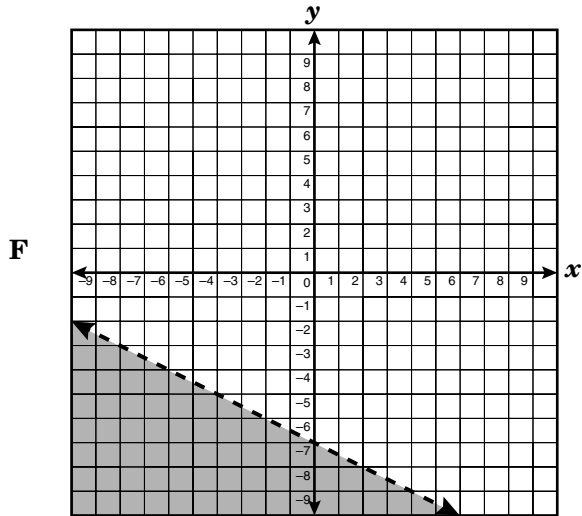

- 21 In the figure shown below, \overline{BC} is parallel to \overline{ED} , and \overline{AE} is perpendicular to \overline{ED} . The measure of $\angle ABC$ is 130° .

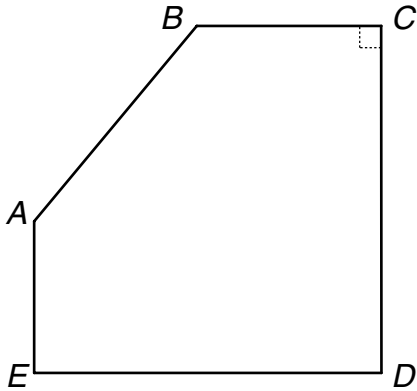

What is the measure of $\angle BAE$ in degrees?

Record your answer and fill in the bubbles on your answer document. Be sure to use the correct place value.

- 22 A wooden pole was broken during a windstorm. Before it broke, the total height of the pole above the ground was 25 feet. After it broke, the top of the pole touched the ground 15 feet from the base.

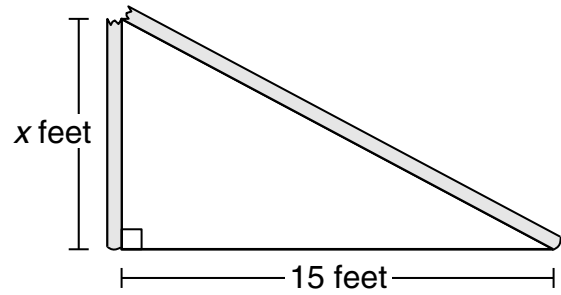

How tall was the part of the pole that was left standing?

- F 8 ft
- G 10 ft
- H 17 ft
- J 20 ft

- 23** A rectangle has a length of 4 feet and a perimeter of 14 feet. What is the perimeter of a similar rectangle with a width of 9 feet?
- A** 36 ft
 - B** 42 ft
 - C** 108 ft
 - D** 126 ft

- 24** Which two 3-dimensional figures have the same number of faces?
- F** A triangular prism and a square pyramid
 - G** A triangular prism and a rectangular prism
 - H** A triangular pyramid and a square pyramid
 - J** A triangular pyramid and a rectangular prism

- 25 Kim walked diagonally across a rectangular field that measured 100 feet by 240 feet.

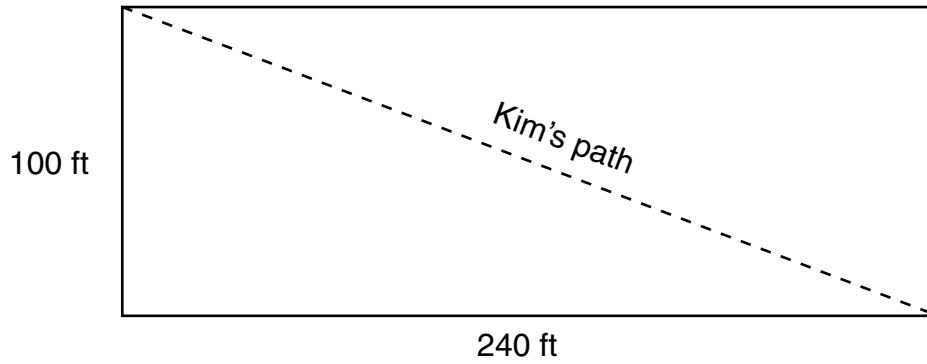

Which expression could be used to determine how far Kim walked?

- A $2(100 + 240)$
- B $\sqrt{100} + \sqrt{240}$
- C $\frac{100 \times 240}{2}$
- D $\sqrt{(100^2) + (240^2)}$
-
- 26 If the surface area of a cube is increased by a factor of 4, what is the change in the length of the sides of the cube?
- F The length is 2 times the original length.
- G The length is 4 times the original length.
- H The length is 6 times the original length.
- J The length is 8 times the original length.

- 27 What is the domain of the function shown on the graph?

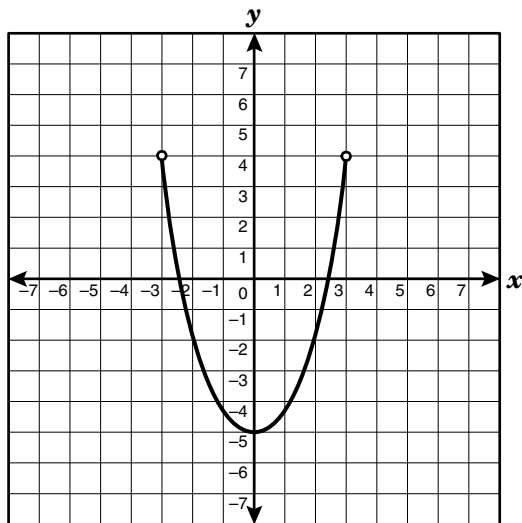

- A $-3 \leq x \leq 3$
 B $-3 < x < 3$
 C $-5 < x \leq 4$
 D $-5 \leq x < 4$

- 28 Marsha brought cookies to school. She gave a third of her cookies to Ana. Ana then gave a fourth of her cookies to Cybil. Cybil gave half of her cookies to Betsy. If Betsy has 2 cookies, how many cookies did Marsha have in the beginning?

- F 18
 G 24
 H 36
 J 48

- 29 The graph of the equation $y = \frac{5}{3}x - 3$ is given below. Graph $y = x + 1$ on the grid.

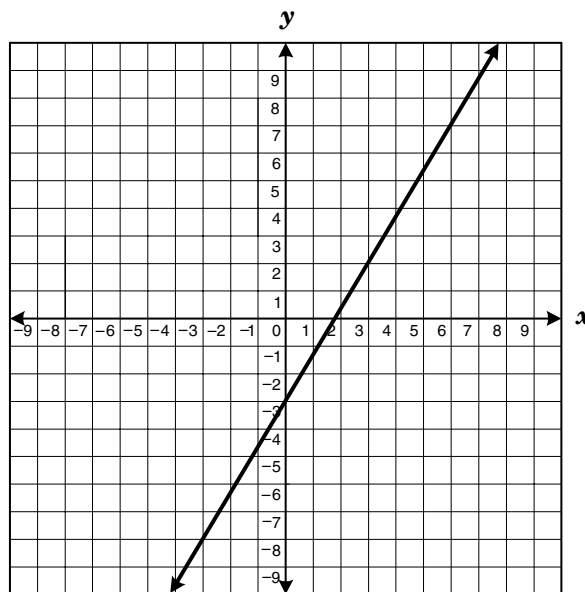

What is the solution to this system of equations?

- A (0, 1)
 B (5, 6)
 C (6, 7)
 D No solution

- 30 As part of a classroom assignment, Kimberly was given this geoboard to model the slope of $\frac{2}{3}$.

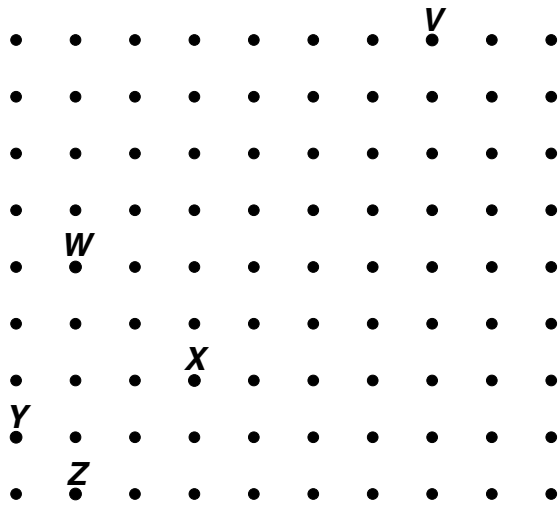

If the peg in the lower left-hand corner represents the origin on a coordinate plane, where could Kimberly place a rubber band to represent the given slope?

- F From peg V to peg W
- G From peg V to peg X
- H From peg V to peg Y
- J From peg V to peg Z

- 31 Which equation best describes the relationship between x and y shown in the table below?

x	y
1	3
2	12
4	48
6	108
9	243

- A $y = 3x$
- B $x = 3y$
- C $x = 3y^2$
- D $y = 3x^2$

- 32 Chase wanted to find 3 consecutive whole numbers that add up to 81. He wrote the equation $(n - 1) + n + (n + 1) = 81$. What does the variable n represent in the equation?

- F The least of the 3 whole numbers
- G The middle of the 3 whole numbers
- H The greatest of the 3 whole numbers
- J The difference between the least and greatest of the 3 whole numbers

33 A leap year occurs when the number of a year is a multiple of 4. However, year numbers that are multiples of 100 are not leap years unless they are multiples of 400. Which is not an example of a leap year?

- A** 2440
- B** 2400
- C** 2340
- D** 2300

34 Which equation is the parent function of the graph represented below?

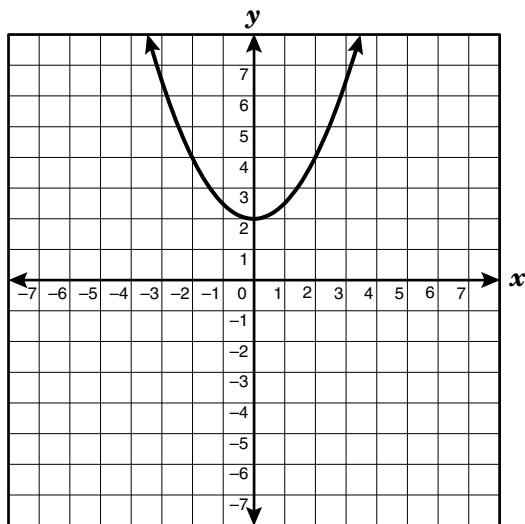

- F** $y = |x|$
- G** $y = x$
- H** $y = x^2$
- J** $y = \sqrt{x}$

35 Two race cars travel at constant speeds in the same direction around a track. The faster car travels 186 miles per hour and completes 50 laps each time the slower car completes 47.6 laps. Which is a reasonable estimate of the slower driver's speed?

- A** Between 180 mph and 185 mph
- B** Between 175 mph and 180 mph
- C** Between 145 mph and 150 mph
- D** Between 135 mph and 140 mph

- 36 For a sports banquet Coach Mackey must use the rectangular tables in the school cafeteria. The diagram below shows the seating arrangements that Coach Mackey can use at 1 and 2 tables.

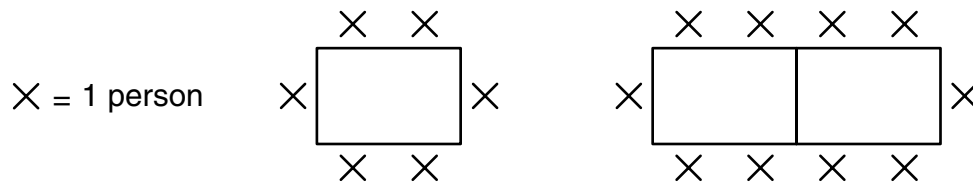

Which expression can be used to determine the number of people who can sit as a group if y tables are joined to form 1 long table?

- F** $6y$
G $4(y + 1)$
H $3(y + 1)$
J $2(2y + 1)$
-
- 37 The completion of a certain chemical reaction is expressed by the equation $y = 250 - 5x - x^2$, where y is the number of seconds needed to complete the reaction and x is the temperature in degrees Celsius at which the reaction occurs. If the reaction is complete in 200 seconds, what is the temperature at which the reaction occurs?

- A** 5°C
B 7°C
C 10°C
D 12°C

- 38 Which of the following is a true statement about the net of the cube shown?

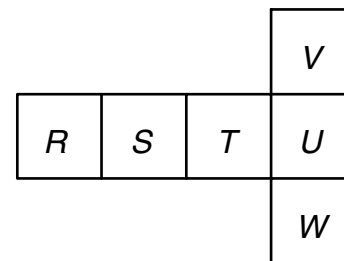

- F** Faces R and S are parallel.
G Faces R and U are parallel.
H Faces S and U are perpendicular.
J Faces T and U are perpendicular.

39 Amber is making a patchwork quilt using 3 different types of fabric. Each type of fabric is cut into rectangles. The first fabric is cut into pieces measuring 3 inches by 5 inches. The dimensions of the rectangles of the second type of fabric are 125% those of the first type, and the dimensions of the third type of fabric are 125% those of the second. What are the approximate dimensions of the third type of fabric?

- A** 3.75 in. by 6.25 in.
- B** 4.69 in. by 7.81 in.
- C** 5.50 in. by 7.50 in.
- D** 4.25 in. by 6.25 in.

40 At a college bookstore, Carla purchased a math textbook and a novel that cost a total of \$54, not including tax. If the price of the math textbook, m , is \$8 more than 3 times the price of the novel, n , which system of linear equations could be used to determine the price of each book?

F $m + n = 8$
 $m = 3n + 54$

G $m + n = 8$
 $m = 3n - 54$

H $m + n = 54$
 $m = 3n + 8$

J $m + n = 54$
 $m = 3n - 8$

41 Which expression is equivalent to $\frac{2}{3}(3x - 15y) + (9y - 11x)$?

- A** $-9x - y$
- B** $11x - 21y$
- C** $10x - 4y$
- D** $-9x - 26y$

42 Which ordered pair represents one of the roots of the function $f(x) = 2x^2 + 3x - 20$?

F $(-\frac{5}{2}, 0)$

G $(-4, 0)$

H $(-5, 0)$

J $(-20, 0)$

- 43 What is the area of the unshaded part of the rectangle below?

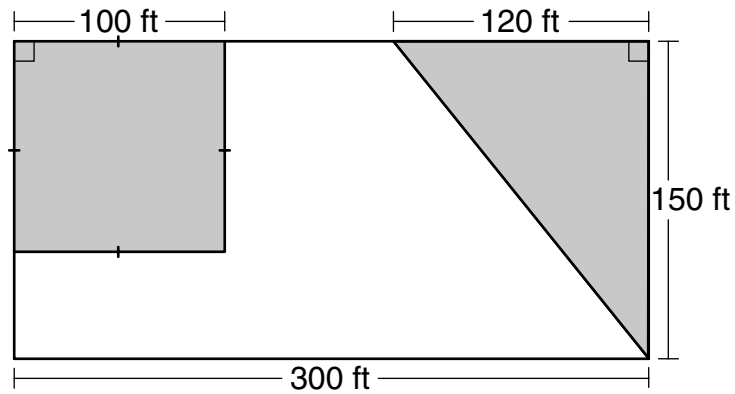

- A 19,000 ft²
- B 45,000 ft²
- C 28,000 ft²
- D 26,000 ft²

- 44 Which equation represents the line that passes through the points $(-1, 4)$ and $(3, 2)$?

F $y = -\frac{1}{2}x + \frac{7}{2}$

G $y = -\frac{1}{2}x + \frac{9}{2}$

H $y = -2x + 7$

J $y = -2x + 3$

- 45 Matt is a speed skater. His coach recorded the following data during a timed practice period.

Time (seconds)	Distance (meters)
4.50	50
9.00	100
11.25	125

If Matt continues to skate at the rate shown in the table, what is the approximate distance in meters he will skate in 25 seconds?

- A 250 m
- B 175 m
- C 150 m
- D 278 m

- 46 The lengths of the bases of an isosceles trapezoid are shown below.



If the perimeter of this trapezoid is 32 units, what is its area?

- F 44 square units
- G 110 square units
- H 88 square units
- J 55 square units

47 The graph below shows the decrease in the value of a personal computer over a period of 60 months.

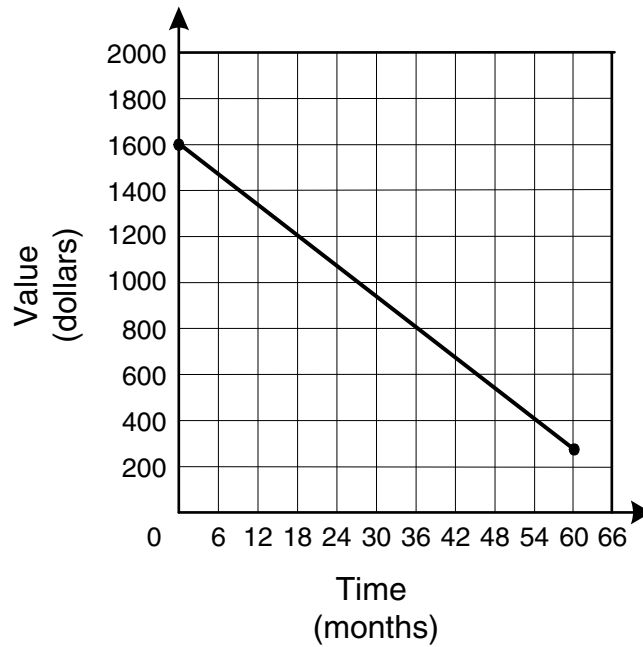

Which is a reasonable conclusion about the value of this personal computer during the time shown on the graph?

- A Its value at 18 months was twice its value at 36 months.
- B Its value at 36 months was half its value at 54 months.
- C It depreciated \$200 every 12 months.
- D It depreciated \$400 every 18 months.

- 48 The amount of an employee's weekly pay, p , including a bonus, can be represented by the inequality $6.00h + 100 < p < 6.50h + 125$, where h represents the number of hours worked by the employee. If an employee worked 25 hours, which of the following is a reasonable amount for that week's pay?
- F** \$118.75
G \$250.00
H \$272.50
J \$290.25

- 49 The table below shows the cost of fertilizer, depending on the amount purchased.

Cost of Fertilizer

Number of Pounds	Cost
5	\$1.95
20	\$6.95
50	\$15.95
100	\$28.95

Which conclusion can be made based on information in the table?

- A** The cost of 10 pounds of fertilizer would be more than \$4.00.
B The cost of 200 pounds of fertilizer would be less than \$57.00.
C The cost of fertilizer is always more than \$0.35 per pound.
D The cost of fertilizer is always less than \$0.30 per pound.

- 50 A hexagon is graphed on the coordinate grid.

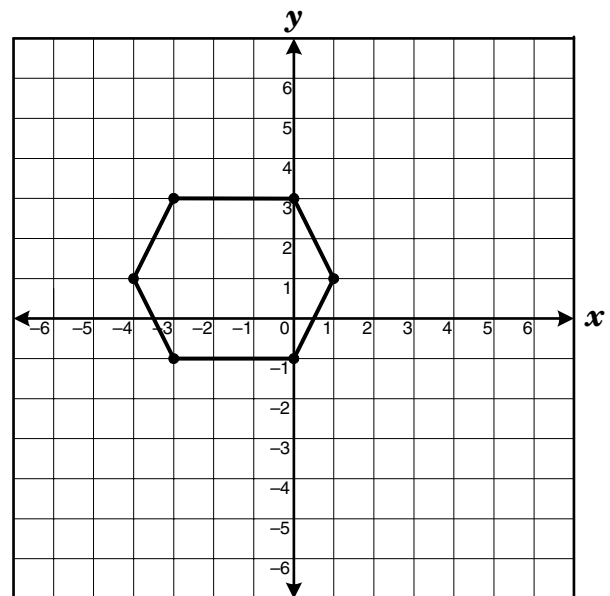

Which two coordinate points lie on the same line of symmetry on this hexagon?

- F** $(-3, -1)$ and $(0, 3)$
G $(-1, 3)$ and $(-1, -1)$
H $(0, 3)$ and $(0, -1)$
J $(-4, 1)$ and $(1, 1)$

51 About how many feet of fencing are needed to enclose a rectangular garden with a 30-foot-long side and a 40-foot-long diagonal?

- A** 113 ft
- B** 133 ft
- C** 140 ft
- D** 160 ft

52 A frozen dinner is divided into 3 sections on a circular plate with a 12-inch diameter.

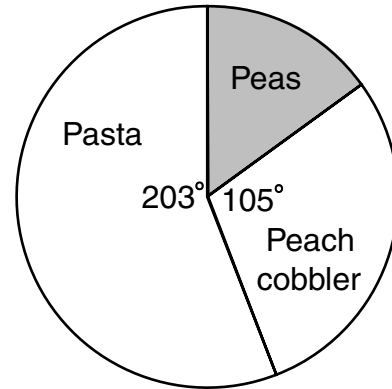

What is the approximate length of the arc of the section containing peas?

- F** 3 in.
- G** 21 in.
- H** 16 in.
- J** 5 in.

53 The price, e , of an entertainment system at Extreme Electronics is \$220 less than twice the price, u , of the same system at Ultra Electronics. The difference in price between the system at Extreme Electronics and Ultra Electronics is \$175. Which system of linear equations can be used to determine the price of the system at each store?

A $2e - u = 220$
 $e - u = -175$

B $2e - u = 220$
 $e + u = 175$

C $2e - 2u = 440$
 $e - u = -175$

D $e - 2u = -220$
 $e - u = 175$

54 The area of a rectangle is $144j^9k^{15}$ square units. If the width of the rectangle is $8j^4k^5$ units, what is the rectangle's length?

F $1152j^{13}k^{20}$ units

G $152j^{13}k^{20}$ units

H $136j^5k^{10}$ units

J $18j^5k^{10}$ units

55 A department store had a 20%-off sale on all clothing items. Which statement best represents the functional relationship between the sale price of an article of clothing and the original price?

A The original price is dependent on the sale price.

B The sale price is dependent on the original price.

C The sale price and the original price are independent of each other.

D The relationship cannot be determined.

- 56 Rectangle $MNPQ$ has diagonals that intersect at point X .

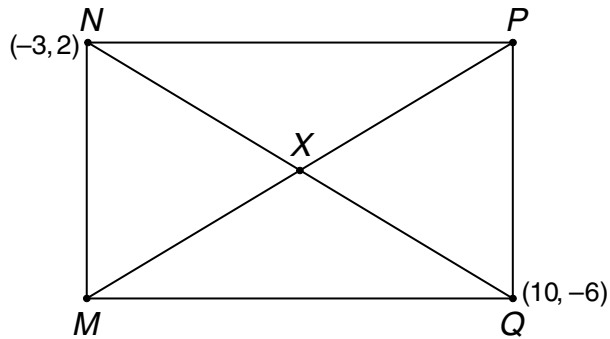

Which of the following represents point X ?

- F $(\frac{7}{2}, -2)$
- G $(\frac{13}{2}, 4)$
- H $(-\frac{13}{2}, -4)$
- J $(-\frac{7}{2}, 2)$

- 57 Line q is shown below.

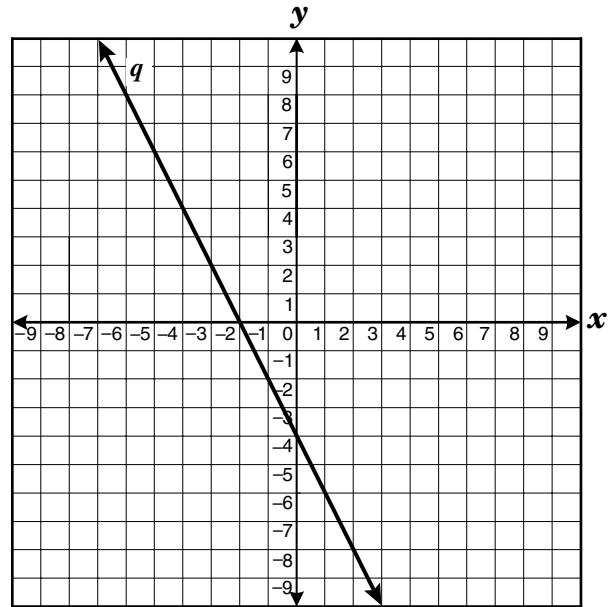

Which equation best represents a line parallel to line q ?

- A $y = -\frac{1}{2}x + 4$
- B $y = \frac{1}{2}x - 3$
- C $y = 2x - 5$
- D $y = -2x + 1$

- 58 A pizza parlor surveyed 100 customers to determine their favorite pizza topping or combination of toppings. The results are shown below.

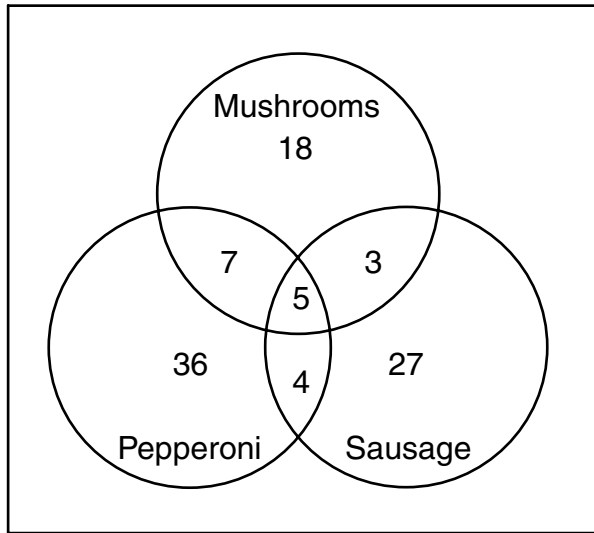

How many of the customers surveyed picked a combination of only 2 toppings as their favorite?

- F** 5
G 7
H 14
J 19
- 59 Which equation will produce the widest parabola when graphed?
- A** $y = 2x^2$
B $y = -6x^2$
C $y = -0.6x^2$
D $y = 0.2x^2$

- 60 Ms. Barton determined that the total cost of her wedding, c , could be represented by the equation $c = 75n + 1500$, where n is the number of people attending the wedding. If Ms. Barton's wedding cost \$8625, how many people attended the wedding?

- F** 135
G 95
H 115
J 75

BE SURE YOU HAVE RECORDED ALL OF YOUR ANSWERS
ON THE ANSWER DOCUMENT.



